



ECHLIN®

WINDOW LIFTS

LOOKS RIGHT.
FITS RIGHT.
PERFORMS RIGHT.

Quality Advantage: Window Lift Motors OE Fit, Form & Function

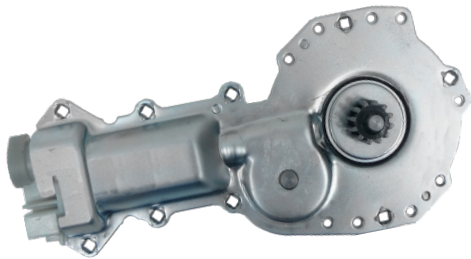

Power Window Motor P/N WLM1001

Window lift motors are involved in the everyday use of a vehicle. Throughout its lifetime, it's subjected to extreme conditions in harsh environments. For this reason, NAPA® Echlin® designs quality units that begin with a comparison to the OE as a baseline for fit, form and function. Field research uncovers unique improvement opportunities that eliminate known inherent weaknesses.

The NAPA® Echlin® Difference

BRUSH HOLDER - OUTSIDE

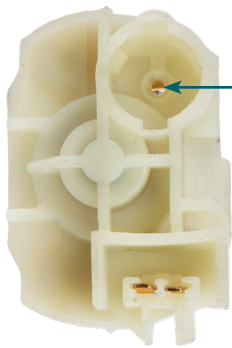

COMPETITOR UNIT
The competitor brush holder will funnel water into the motor causing rust, corrosion and premature failure.

NAPA® ECHLIN UNIT

The NAPA® Echlin® brush holder is GM®'s latest design with a revised vent hole and water entry prevention.

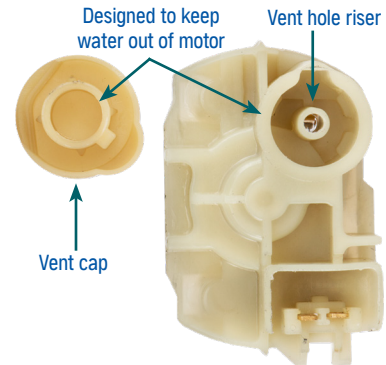

BRUSH HOLDER - INSIDE

COMPETITOR UNIT

The competitor unit visibly shows lack of lubrication on the armature shaft and thrust bearing. This can result in premature failure. Their brush holder design allows the circuit breaker to make direct contact with the commutator. This can result in shorting and motor failure.

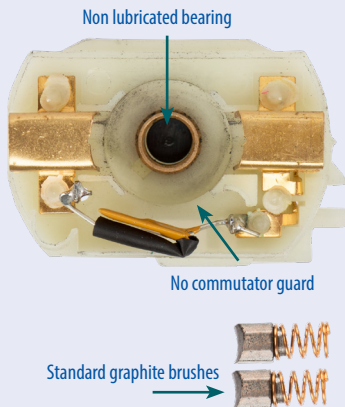

Standard graphite brushes

NAPA® ECHLIN UNIT

NAPA® ECHLIN UNIT

The NAPA® Echlin® unit is thoroughly lubricated for increased performance and durability. A special pocket design protects the commutator and circuit breaker from making contact.

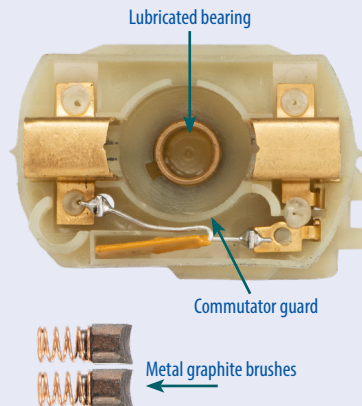

Metal graphite brushes

NAPA® Echlin® motors are tested to 15 years of simulated real world use!

The NAPA® Echlin® Advantage

Power Window Motor P/N WLM1001

ARMATURE & BEARING

COMPETITOR UNIT

Lower performing motors are noticeable in vehicles with large heavy windows. This is shown by slower window operation and high current draw.

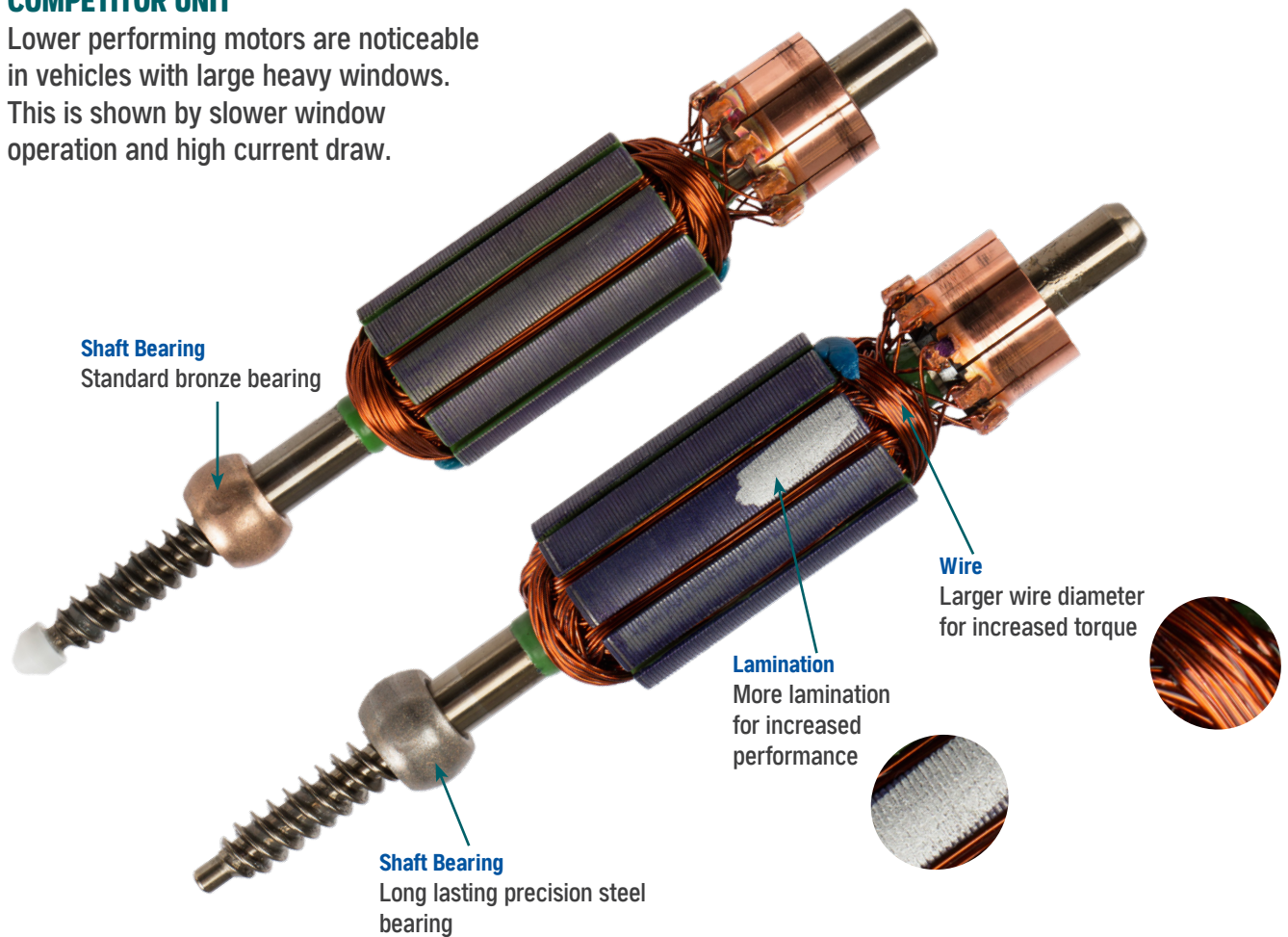

NAPA® ECHLIN® UNIT

NAPA® Echlin® designed this unit with a 25% increase in torque and speed over the competitor. This means a more efficient motor to quickly power window operation.

Clutch Spring

NAPA® Echlin® utilizes a larger spring wire which is critical to prevent the motor from reversing when power is off.