



ECHLIN®

DID YOU KNOW?

NEW Mass Air Flow (MAF) Sensors

The Mass Air Flow (MAF) sensor measures the amount of airflow entering the intake manifold and must communicate clearly with the Engine Control Module (ECM). To ensure accurate airflow, precise performance, and longer service life, NAPA® Echlin® offers a line of **100% NEW, never remanufactured, MAF Sensors**. All NAPA® Echlin-manufactured MAF Sensors are engineered and built in our vertically integrated TS16949-certified facility.

NEW
NOT
REMAN

Our Choked Air Flow Calibration and Test System ensures precise mass airflow output to match the OE so you can install NAPA® Echlin® **NEW** MAF Sensors with confidence. As a result, our Sensors match the OE output precisely, and perform flawlessly under all operating conditions, every time.

160+
SKUs

NAPA® Echlin® offers more than 160 **NEW**, never remanufactured, MAF sensors. In total, our line provides greater than 90% coverage for all domestic and import MAF-equipped vehicles. That's industry-leading coverage.

Features and Benefits: NAPA® Echlin® Manufactured **NEW** MAF Sensors

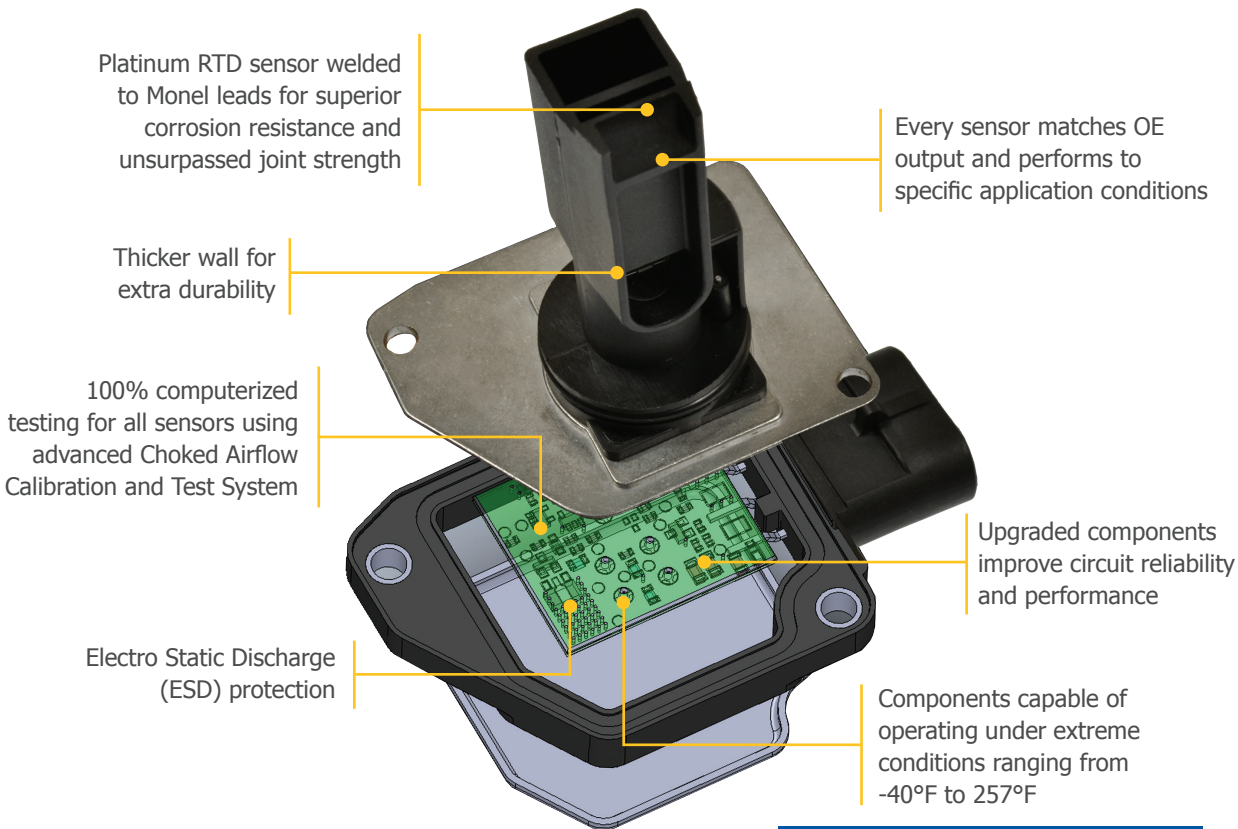

Ford



GM



Hyundai



Toyota



Honda



Nissan

TESTING UPDATES ON REVERSE SIDE



LOOKS RIGHT. FITS RIGHT. PERFORMS RIGHT.

NAPAEchlin.com

NE10235MAF



ECHLIN®

DID YOU KNOW?

Why MAF Sensor Testing and Calibration Matters

One of the most important factors for MAF sensor performance is precise testing and calibration. This is what sets NAPA® Echlin® apart from the rest. With onsite engineering, design, and test labs at our ISO/TS16949- and ISO14001-certified manufacturing facility, NAPA® Echlin® is able to produce 100% new MAF sensors that precisely match the OE output and perform flawlessly under all operating conditions. Here are just a few of our testing and calibration techniques:



Choked Airflow Testing and Calibration
accurately measures and calibrates our new MAF sensors



Salt and Chemical Contamination Testing
ensures MAF sensors withstand harsh environmental conditions



On-Vehicle Road and Vibration Testing
ensures performance and durability in real-world conditions

The Importance of the RTD Sensor

In addition to testing and calibration, another important factor for MAF sensor performance is the use of high-quality RTD sensors. All NAPA® Echlin-manufactured MAF sensors feature custom-designed, platinum flow RTD sensors that precisely match OE outputs, and temperature RTD sensors that match OE specifications more closely than the diodes used by some competitors. Plus, the pull strength of our RTD lead joints not only matches the OE, but exceeds the aftermarket competition. Our RTD components also don't break under extreme vibration.

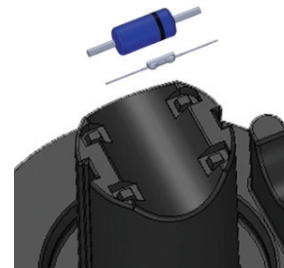

CAD image of our custom-designed platinum RTD sensors

NAPA® Echlin®
Custom-designed platinum RTD sensors outperforms the aftermarket competition in vehicle road, air flow, and high-temp degradation testing, which results in proper drivability.



Competitor
Low-quality RTD sensors failed our vehicle road, air flow, and high-temp degradation tests, resulting in noticeable drivability issues.



LOOKS RIGHT. FITS RIGHT. PERFORMS RIGHT.

NAPAEchlin.com