



ECHLIN®

EVAP COMPONENTS

WHAT'S IN YOUR BOX?

NAPA® Echlin® EVAP components are engineered to match OE performance and keep vehicles running clean

Evaporative emission systems on today's vehicles require each and every component to work correctly to keep emissions low. That is why NAPA® Echlin® designs and manufactures the highest-quality and best-performing evaporative emissions components in the industry.

What's inside the NAPA® Echlin® box... advanced engineering, precision manufacturing, extensive testing, and on-vehicle validation. What's in your box?

NAPA® Echlin® EVAP components also include design improvements to enhance durability while keeping the system operating exactly as the vehicle manufacturer intended. Canister Purge Valves, Fuel Vapor Canisters, Canister Vent Solenoids and more, NAPA® Echlin's complete line of precision-engineered EVAP components provides the coverage you need to keep vehicles running clean.



1,300+
SKUs

NAPA® Echlin® offers more than 1,300 EVAP part numbers, including related components, for a complete EVAP system service

100%
TESTED & VALIDATED

NAPA® Echlin® EVAP components are subjected to rigorous lab testing and are validated on actual vehicles



NAPA® Echlin® EVAP components work as the OE intended to reduce harmful emissions

Matches OE performance, with design improvements for durability

OE PROBLEM:

The plunger inside of the OE solenoid can become distorted, resulting in additional wear on one side of the plunger. This can cause the plunger to crack and leak fuel vapors.

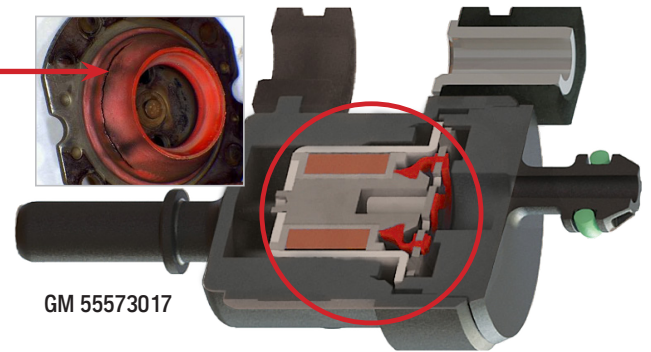

GM 55573017

NAPA ECHLIN SOLUTION:

We added an internal bobbin to the plunger so it runs true and doesn't one side of the plunger

By keeping the plunger in alignment, wear is reduced, resulting in a longer-lasting component

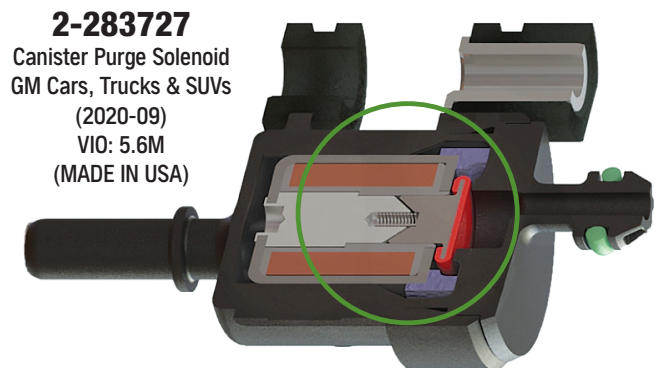

2-283727

Canister Purge Solenoid
GM Cars, Trucks & SUVs
(2020-09)
VID: 5.6M
(MADE IN USA)

NAPA® Echlin's EVAP Emission Program Includes:

- Canister Purge Solenoids
- Canister Purge Valves
- Canister Vent Solenoids
- Canister Vent Valves
- ESIMs
- Fuel Vapor Canisters
- Fuel Vapor Canister Seals
- Fuel Vapor Canister Filters
- Fuel Vapor Leak Detection Pumps
- Fuel Vapor Leak Detection Pump Filters
- Vapor Canister Vent/Purge Valve Hoses



ECHLIN

LOOKS RIGHT. FITS RIGHT. PERFORMS RIGHT.

NAPAEchlin.com